



SOTTOVUOTO VACUUM PACKAGING EASY line



EASY line
EASY line
EASY line
EASY line
EASY line
EASY line
EASY line
EASY line
EASY line
EASY line

PACK 250



Barra saldante - Sealing bar - Barre de scellement - Schweißleiste - Barra soldadora	mm	250
Vasca - Pan - Bac - Wanne - Cuba	mm	260x330x 95+65 h
Pompa vuoto - Vacuum pump - Pompe à vide - Vakuumpumpe - Bomba de vacío	mc/h	4
Potenza - Power - Puissance - Leistung - Potencia	kW (HP)	0,12 (0,16)
Peso - Weight - Poids - Gewicht - Peso	kg	34

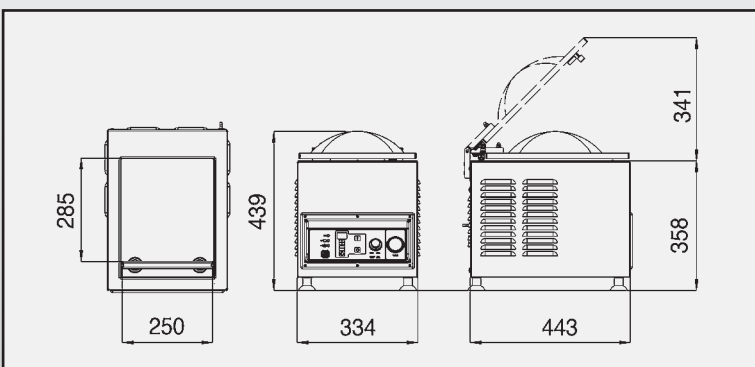

Barra saldante - Sealing bar - Barre de scellement - Schweißleiste - Barra soldadora	mm	310
Vasca - Pan - Bac - Wanne - Cuba	mm	320x350x 115+65 h
Pompa vuoto - Vacuum pump - Pompe à vide - Vakuumpumpe - Bomba de vacío	mc/h	8
Potenza - Power - Puissance - Leistung - Potencia	kW (HP)	0,25 (0,33)
Peso - Weight - Poids - Gewicht - Peso	kg	47

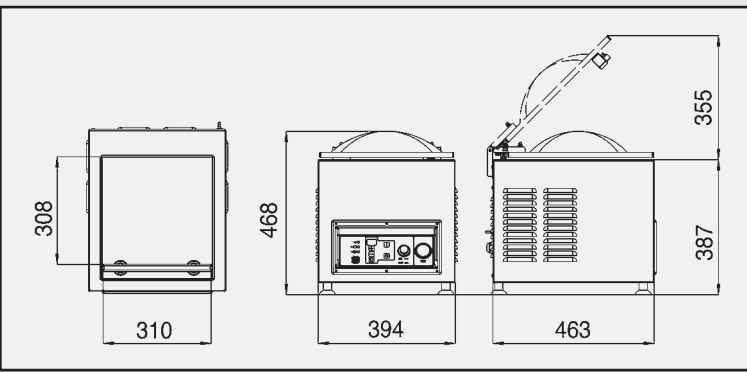

PACK 310



2 barre saldanti - 2 sealing bars - 2 barres de scellement - 2 Schweißleiste - 2 barras soldadoras	mm	350
Vasca - Pan - Bac - Wanne - Cuba	mm	360x405x 115+65 h
Pompa vuoto - Vacuum pump - Pompe à vide - Vakuumpumpe - Bomba de vacío	mc/h	12
Potenza - Power - Puissance - Leistung - Potencia	kW (HP)	0,60 (0,80)
Peso - Weight - Poids - Gewicht - Peso	kg	55

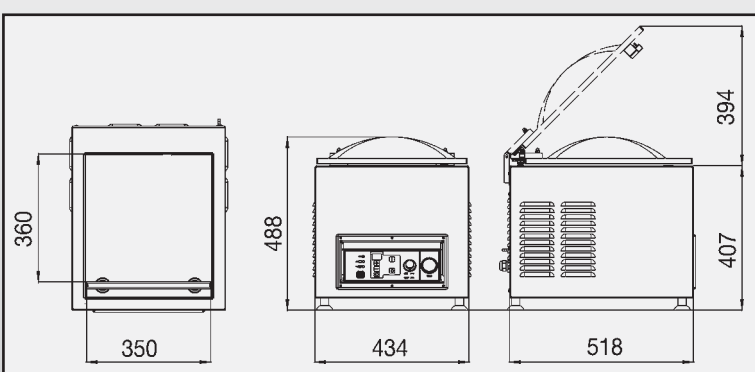

PACK 350



PACK 415



Barra saldante - Sealing bar - Barre de scellement - Schweißleiste - Barra soldadora	mm	415
Vasca - Pan - Bac - Wanne - Cuba	mm	435x520x115+85 h
Pompa vuoto - Vacuum pump - Pompe à vide - Vakuumpumpe - Bomba de vacío	mc/h	18
Potenza - Power - Puissance - Leistung - Potencia	kW (HP)	0,75 (1,00)
Peso - Weight - Poids - Gewicht - Peso	kg	80

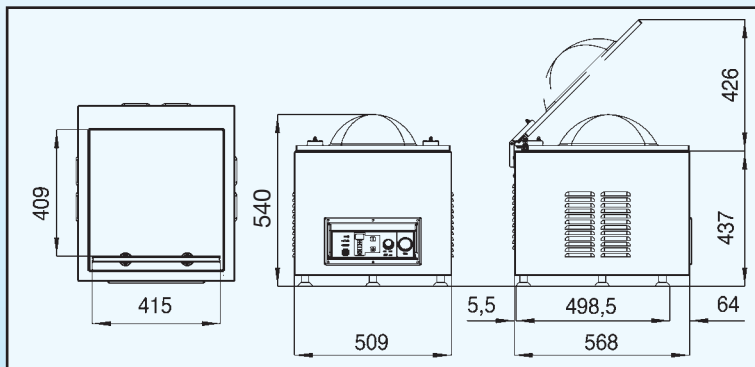

Barra saldante - Sealing bar - Barre de scellement - Schweißleiste - Barra soldadora	mm	460
Vasca - Pan - Bac - Wanne - Cuba	mm	470x530x115+100 h
Pompa vuoto - Vacuum pump - Pompe à vide - Vakuumpumpe - Bomba de vacío	mc/h	18
Potenza - Power - Puissance - Leistung - Potencia	kW (HP)	0,75 (1,00)
Peso - Weight - Poids - Gewicht - Peso	kg	90

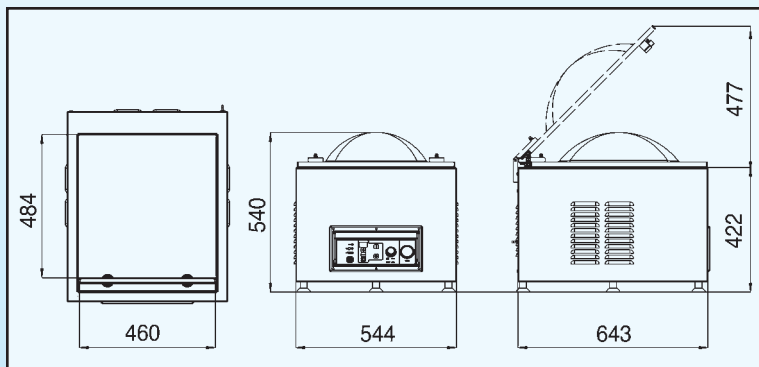

PACK 460



Barra saldante - Sealing bar - Barre de scellement - Schweißleiste - Barra soldadora	mm	460
Vasca - Pan - Bac - Wanne - Cuba	mm	470x530x115+100 h
Pompa vuoto - Vacuum pump - Pompe à vide - Vakuumpumpe - Bomba de vacío	mc/h	25
Potenza - Power - Puissance - Leistung - Potencia	kW (HP)	1,10 (1,48)
Peso - Weight - Poids - Gewicht - Peso	kg	110

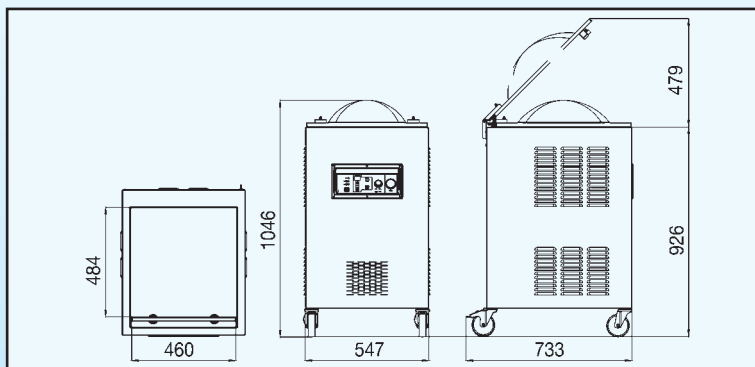

PACK 460C



EASY line

EASY line

EASY line

EASY line

EASY line

EASY line

EASY line

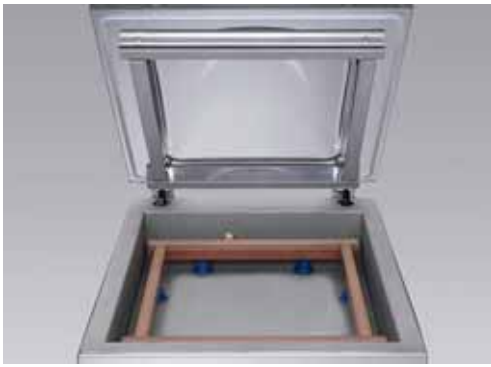

CONFIGURAZIONI DELLE BARRE - CONFIGURATION OF BARS - CONFIGURATIONS DES BARRES
 KONFIGURATIONEN DER SCHWEIßLEISTEN - CONFIGURACIONES DE LAS BARRAS

Standard

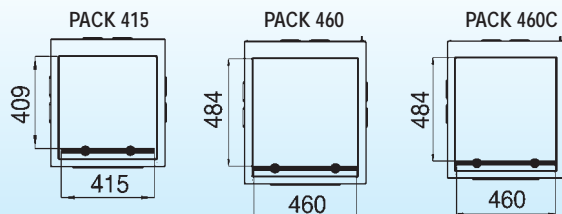
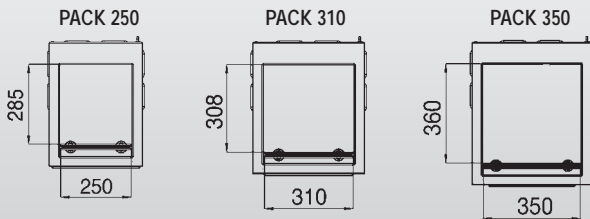

Optional

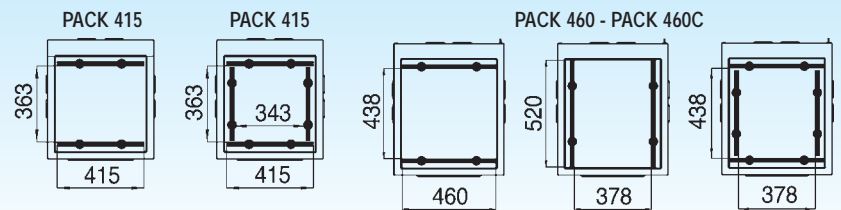

Il movimento della barra saldante è comandato da due pistoni che si muovono perfettamente in parallelo. Non ci sono contatti con fili volanti. Le barre si estraggono facilmente per la pulizia.



The movement of the sealing bar is controlled by two pistons that move in a perfectly parallel way. No contact possible with free cables. The bars may be easily removed for cleaning.



Le mouvement de la barre de scellage est commandé par deux pistons dont le déplacement est rigoureusement parallèle. Absence de contacts avec les câbles libres. Les barres peuvent être extraites sans difficulté aucune pour procéder à leur nettoyage.



Die Bewegung der Schweißleiste wird durch zwei Kolben gesteuert, die sich absolut parallel bewegen. Es gibt keinen Kontakt mit fliegenden Leitungen. Die Leisten können zur Reinigung leicht entnommen werden.



El movimiento de la barra soldadora es gobernado por dos pistones que se mueven perfectamente en paralelo. No existen contactos con cables volantes. Las barras pueden extraerse fácilmente para efectuar la limpieza.

DOTAZIONI STANDARD ED OPZIONI - STANDARD AND OPTIONAL FEATURES - FOURNITURES STANDARD ET OPTIONS - STANDARD AUSRÜSTUNG UND OPTIONEN - EQUIPAMIENTO ESTÁNDAR Y OPCIONALES

	PACK 250	PACK 310	PACK 350	PACK 415	PACK 460	PACK 460C
Vasca inox - Stainless steel chamber - Bac inox - Edelstahlwanne - Cuba inox	○	○	○	○	○	○
Portata pompa a vuoto - Vacuum pump capacity - Débit pompe à vide - Vacuum Pumpe Leistung - Caudal bomba vacío	4 mc/h	8 mc/h	12 mc/h	18 mc/h	18 mc/h	25 mc/h
Pompa con maggiore portata - Greater capacity pump - Pompe avec débit supérieur - Pumpe mit Höherer Kapazität - Bomba con caudal mayor	6 mc/h	12 mc/h	18 mc/h	25 mc/h	25 mc/h	40 mc/h
Pannello comandi - Control panel - Panneau de commande - Bedientafel - Panel de mando	led	led	led	led	led	led
Preriscaldamento pompa - Pump pre-heating - Préchauffage pompe - Pumpenvorheizung - Precalementamiento bomba	○	○	○	○	○	○
Programmazione tempo di aspirazione - Suction time setting - Programmation temps de aspiration - Programmierung Aspirationszeit - Programación tiempo de aspiración	○	○	○	○	○	○
Programmazione tempo di saldatura - Sealing time setting - Programmation temps de soudure - Programmierung Schweissungszeit - Programación tiempo de soldadura	○	○	○	○	○	○
Programmi uso utente - User programs - Programmes d'utilisation - Benutzerprogramme - Programas uso usuario	10	10	10	10	10	10
Controllo manuale tempo di saldatura - Sealing time manual check - Controle manuel de la soudure - Manuelle Steuerung Schweissungszeit - Control manual tiempo de soldadura	○	○	○	○	○	○
Kit iniezione gas - Gas injection kit - Kit injection gaz - Satz Gaseinblasung - Kit de inyección gas *	●	●	●	●	●	●
Taglio sfrido - Seal w/cut-off - Coupe chute - Kantenabschnitt - Corte viruta	●	●	●	●	●	●
Barre saldanti aggiuntive - Additional sealing bars - Barres de scellement supplémentaires - Zusatz-Schweißleisten - Barras soldadoras adicionales	—	—	—	●	●	●
Aspirazione da contenitori esterni - Aspiration from external containers - Aspiration dans des recipients externes - Ansaugung von Aussenbehältern - Aspiración desde recipientes externos	●	●	●	●	●	●
Set tavolette riempimento - Set of filling boards - Jeu tablettes de remplissage - Satz Abfülltablettes - Juego tablas de llenado	○	○	○	○	○	○

○ standard ● optional — non disponibile
not available

ATMOSFERA PROTETTIVA (MAP)



Il confezionamento in atmosfera protettiva si ottiene iniettando nella confezione una miscela di gas, dopo avere effettuato il vuoto. Questa modalità permette di confezionare anche materiali molli, fragili, friabili, che verrebbero altrimenti schiacciati dalla pressione dell'aria all'apertura del coperchio, e crea un ambiente ostile allo sviluppo della flora batterica, prolungando il tempo di conservazione.



PROTECTIVE ATMOSPHERE (MAP)

Protective atmosphere packaging consists in the injection of a gas mixture inside a package after all the air has been drawn out. This method makes it possible to package soft, fragile or crumbly materials that would otherwise be crushed by the air pressure as the container is opened and creates a hostile environment hindering the growth of bacterial flora, thereby extending storage life.

ATMOSPHÈRE PROTECTRICE (MAP)



Le conditionnement sous atmosphère protectrice est obtenu en injectant dans l'emballage un mélange de gaz une fois le vide créé. Cette opération permet également de conditionner des produits mous, fragiles et friables qui différemment seraient écrasés par la pression de l'air lors de l'ouverture du couvercle. Elle permet également de créer un environnement hostile au développement de la flore bactérienne et de prolonger ainsi la durée de conservation.



SCHUTZATMOSPHERE (MAP)

Die Verpackung in Schutzatmosphäre erhält man durch Absaugen der Luft in der Verpackung und Einblasen einer Gasmischung. Auf diese Weise können auch weiche, zerbrechliche oder spröde Materialien verpackt werden, die sonst durch den Luftdruck beim Öffnen des Deckels zerdrückt würden; zusätzlich wird eine für die Entwicklung der Bakterienflora ungünstige Umgebung geschaffen, was die Haltbarkeitsdauer erhöht.

ATMÓSFERA PROTECTORA (MAP)



El envasado en atmósfera protectora se obtiene inyectando una mezcla de gas en el envase, después de haber efectuado el vacío. Esta modalidad permite envasar también materiales blandos, frágiles o quebradizos, que de otro modo serían aplastados por la presión del aire al abrirse la tapa; además, crea un ambiente hostil para el desarrollo de la flora bacteriana, con lo que se prolonga el tiempo de conservación.



* Supplemento "kit iniezione gas": a causa del pericolo di deflagrazione non è possibile usare miscele con percentuali di ossigeno superiori a quelle normalmente presenti nell'aria (circa 21%). Decliniamo ogni responsabilità per un uso non conforme alle raccomandazioni e alle istruzioni contenute nel manuale d'uso.

**"Gas injection kit" supplement: due to the risk of fire, it is forbidden to use mixtures with a percentage of oxygen exceeding that normally found in the air (21% approx). We do not accept any responsibility for events arising from use that is contrary to the recommendations contained in the user manual.

* Supplément "kit injection gaz": à cause du danger de déflagration, il n'est pas possible d'utiliser des mélanges avec des pourcentages d'oxygène supérieurs à ceux normalement présents dans l'air (environ 21%). Nous déclinons toute responsabilité pour un usage non conforme aux recommandations et aux instructions figurant dans le manuel d'utilisation.

* Satz "Gaseinblasung": Aufgrund der Explosionsgefahr ist es nicht möglich, Mischungen mit einem Sauerstoffanteil über dem normalerweise in der Luft vorhandenen Prozentsatz (21%) zu verwenden. Wir übernehmen keinerlei Verantwortung für eine nicht mit den Empfehlungen und Anweisungen in dieser Bedienungsanleitung übereinstimmende Verwendung.

* Supplemento "kit de inyección gas": a causa del peligro de explosión, no se pueden utilizar mezclas con porcentajes de oxígeno superiores al normalmente presente en el aire (aproximadamente 21%). Se declina toda responsabilidad en caso de uso no conforme a las recomendaciones e instrucciones contenidas en el manual de uso.



Aishwarya Consolidates Pvt. Ltd.,
#19, Frist Floor, 10th 'B' Main, 27th Cross,
Third Block Jayanagar, BANGALORE - 560 011, INDIA
Tel: +91-80-2664 1200/1/2 Fax: +91-80-2664 1204
E-mail : aishtek@vsnl.com www.aishwaryaconsolidates.com